



# USER INSTRUCTIONS

## COUNTERTOP ICE & WATER DISPENSER

FDFD10501



SAFETY INSTRUCTIONS .....	2	
FEATURES & SPECIFICATIONS .....	4	
CONTROL & DISPENSER .....	6	
DISPENSER CARE .....		
1	1	1
INSTALLATION INSTRUCTIONS .....	14	
TROUBLESHOOTINGS.....	17	
SERVICE & IMPORTANT NOTICE .....	20	

### GENERAL OPERATING INSTRUCTION

**Read these instructions before use and save them for future reference. Let the unit rest and unplugged for 24 hours before use.**

- Remove all external and internal packaging materials. Be sure that all parts have been included before discarding any packaging materials. You may want to keep the packaging materials for use at a later date.
- Upon receipt and inspection of the unit, the power cord must be replaced if it is damaged.

- Contact our customer service at 800-433-9938 or [info@floridaappliances.com](mailto:info@floridaappliances.com)

## SAFETY INSTRUCTIONS

### Electrical Safety

<b>DANGER</b>	<b>Improper use of the power cord plug can result in the risk of electrical shock, property damage and personal injury or death.</b>
---------------	--

- This appliance is equipped with a 3-prong grounding-type plug, and shall be plugged into a properly connected grounding-type outlet.
- It is required to use a 3-prong grounding-type electrical outlet properly grounded in accordance with the National Electrical Code and local codes and ordinances.
- A separate adequately fused and grounded circuit shall be used for this appliance. The voltage rating must match the rating label on the unit.
- Do not use an adapter or an extension cord.
- Do not under any circumstances cut or remove the third ground prong from the power cord.
- Never unplug the appliance by pulling the power cord. To disconnect the unit, always grip the plug firmly and pull straight out from the wall outlet.
- Do not operate the appliance if the appliance housing is removed or damaged.
- Do not attempt to repair or replace any part of your appliance unless it is specifically recommended in this manual. All other servicing shall be referred to a qualified technician.
- To protect against electric shock, do not immerse appliance, plug or cord into water or other liquids.

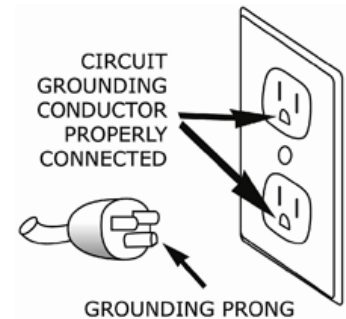

### Child Safety

- Exercise caution and use reasonable supervision when appliance is used near children. Never allow children to operate, play with or crawl inside the unit. Keep packing materials away from children.
- Keep fingers out of pinch point areas and be careful when closing doors if children are around.

### Hot Water Safety

<b>DANGER</b>	<b>This unit can dispense hot water. Hot water can burn your hands and body and cause serious injury.</b>
---------------	---

- To avoid hot water spilling, always put a cup under the dispenser before

you press the button to dispense hot water.

## Cleaning

<b>DANGER</b>
---------------

<b>To reduce the risk of injury when cleaning your appliance, follow these basic precautions.</b>
---

- Unplug the appliance or disconnect power before performing any maintenance or cleaning.
- Do not clean appliance with flammable fluids. Do not store or use gasoline or other flammable vapors or liquids in the vicinity of this or any other unit. The fumes can create a fire hazard or explosion.
- Do not use solvent-based cleaning agents or abrasives on the interior or exterior of the appliance. These cleaners may damage or discolor the appliance.
- Do not operate the appliance with wet hands, while standing on a wet surface or while standing in water.

## Moving

<b>DANGER</b>
---------------

<b>To reduce the risk of injury when moving your appliance, follow these basic precautions.</b>
---

- Exercise caution when moving and installing the appliance. The unit is heavy, to prevent strain or injury, it may require two or more people to move the unit.
- Remove all ice, empty water and secure all loose shelves before you transport the unit. Use protective materials to prevent the glass shelves from being damaged.

## Disposing

<b>DANGER</b>
---------------

<b>When disposing of refrigerated appliances, special handling is often required. It is the consumer's responsibility to comply with federal and local regulations when disposing of this product.</b>
--

- Keep the carton, plastic bags and any exterior wrapping materials in a safe place where children cannot reach them. If you don't need these materials, destroy or recycle them. These items may cause suffocation to children.
- To avoid entrapment and suffocation, before you discard this appliance, remove the doors and leave the shelves in place, so that children may not climb inside.

# FEATURES & SPECIFICATIONS

## Overview

This is a great appliance to help you prepare hot or cold beverages and drinks. The FDFD10501 countertop ice and water dispenser is an innovative design that combines cubed and crushed ice with hot and room-temperature water in a single compact product. The freezer keeps 9 lbs of crescent ice cold and available anytime. The plumbed filtered water system creates the flexibility to place it anywhere in the office, break room, hotel and home. Stainless look or black doors with silver accents give a sleek and modern appearance.

## Features and Parts

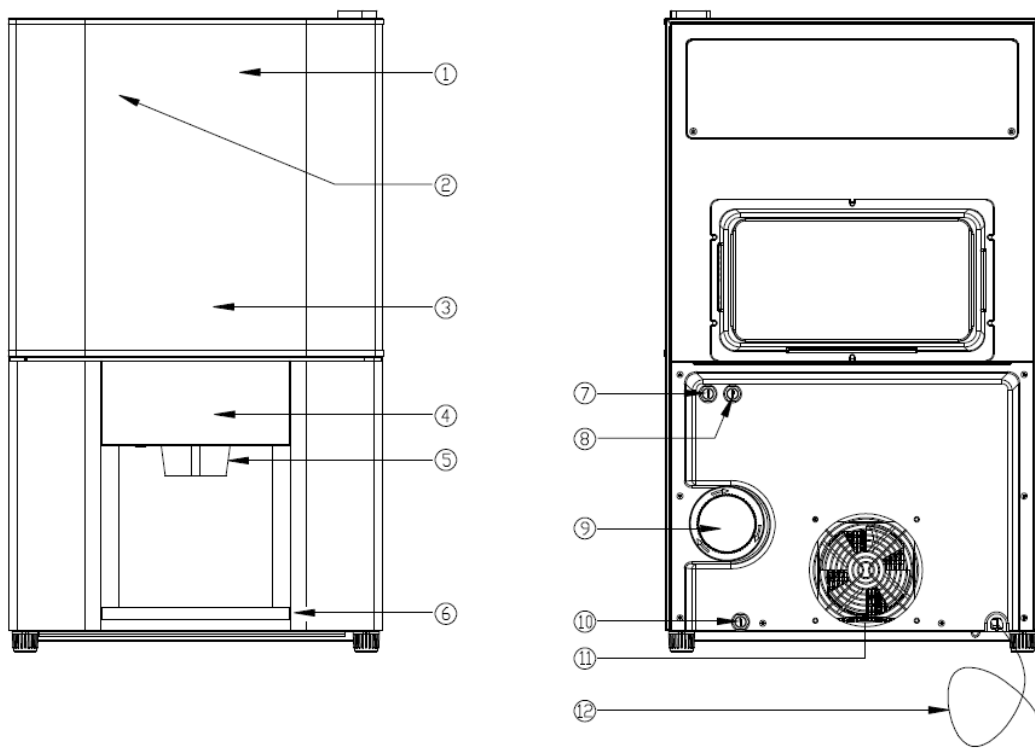

1. Freezer Door
2. Ice Maker (located inside)
3. Ice Bin (located inside)
4. Display Panel
5. Ice and Water Dispenser
6. Dispenser Tray
7. External Filtered Water Line Connector
8. Plumbed Municipal Water Line Connector
9. Water Filter Cover
10. Water Release Drain
11. Condenser Fan
12. Power Cord

- The dispenser allows you to enjoy cubed or crushed ice and hot or iced water with the touch of a button.
- The two-evaporator cooling system and the ice freezer keep ice from melting and produce ice quicker.
- The plumbed filtered water supply provides you with clean and great tasting water.
- Adjustable temperature hot water brings more precise to your hot favorite recipes.
- Touch control brings you the simplicity to select and dispense your preferred types of ice and water.
- Blue display and bright LED lights make it easy to use anytime and attractive to display anyplace.
- On/Off buttons save energy and give you the flexibility to use ice and hot water.
- Automatic alerts for water and filter will not allow you to run out of water or leave water contaminated.
- Child safety design protects your children from burning.

### Specifications and Dimensions

Model No	FDFD10501
Ice Type	Cubed and Crushed
Ice Production Rate (70°F Air/50°F Water)	Crescent Ice 11 lb / 24 h
Ice Bin Capacity	9 lb
Water Type	Hot and Room-Temperature
Hot Water Temperature	Adjustable 122~192 °F
Hot Water Capacity	68 FL OZ
Operating Temperature for Ice	50~110 °F
Water Supply	Plumbed Filtered Water
Electrical Rating	115V/60HZ/5.6A
Unit Dimensions	18-1/8"W x 22-3/8"D x 31-1/2"H
Depth w/ Door Open 90 Degree	39-3/8"
Net Weight	90 lb

## CONTROL & DISPENSER

<b>DANGER</b>	Hot water can burn your hands and body and cause serious injury.
<b>CAUTION</b>	Do not store food and drink in the ice freezer.
<b>NOTE</b>	For the first time use, allow 24 hours to produce the first batch of ice. Discard the first three batches of ice produced.
<b>NOTE</b>	For the first time use or after connecting a plumbed water source or after replacing the water filters, flush the water system by dispensing several cups of water, then discarding them. Repeat until water is clear and tasting good .

### Indicator and Display Functions

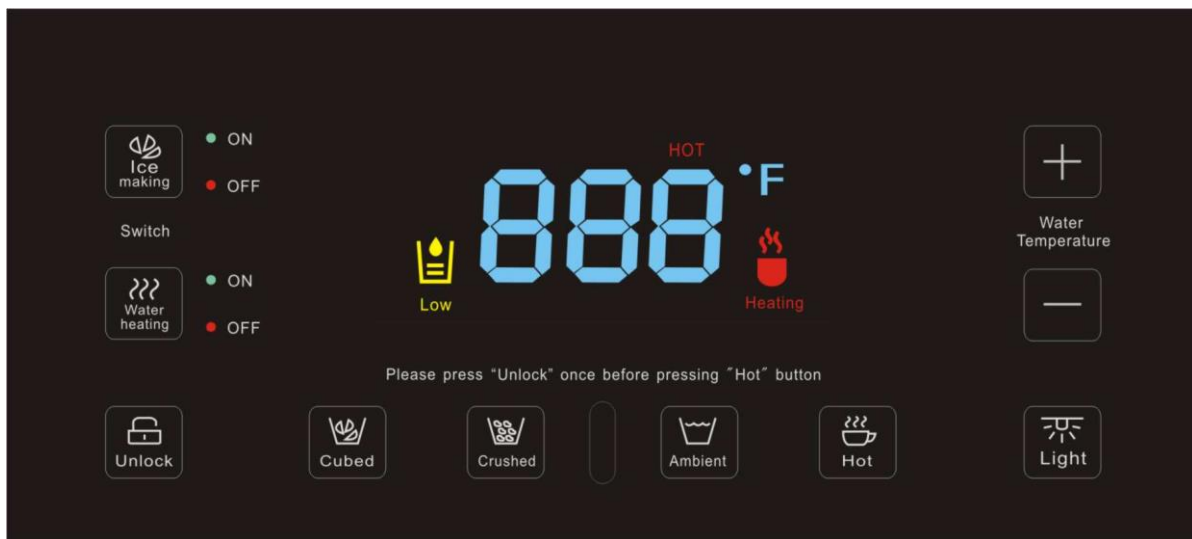

Water heater indicator



Low water level indicator



Hot water temperature display

## Use of the Dispenser

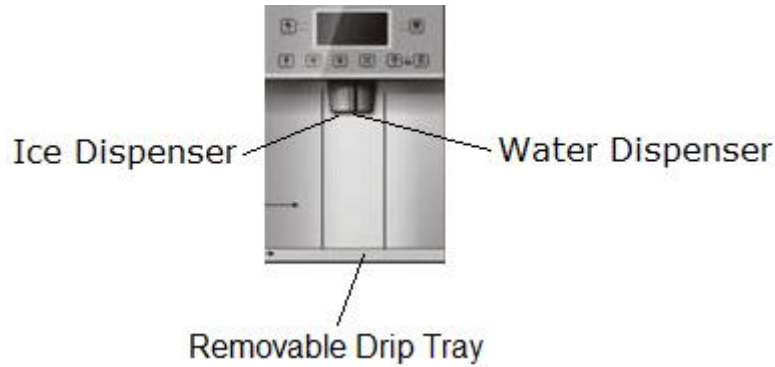

- Once the unit is powered, the ice and hot water functions will be turned on and "ON" green LEDs will light accordingly.
- The water inlet valve opens immediately to let water flow into the internal water tank.
- Once the internal water tank is full, the ice maker and water heater will start working immediately. If the water tank is not filled with water within 4 minutes, the "Low" indicator will appear, and the water inlet valve, water heater, ice maker and water dispensers will stop working.
- While the water heater is on, the "Heating" indicator will appear and the water temperature will be displayed.
- The cooling system will start working in 5 minutes. The cooling system will stop working automatically when ice is being ejected.

## Adjusting the hot water temperature



Hot water temperature setting buttons

- Press "+" or "-" button once to enter temperature setting mode, the temperature display will start flashing and show the current setting.
- Press "+" or "-" button once to adjust temperature in 1 degree increment or decrement, or press and hold "+" or "-" button until the proper temperature is displayed.
- Once "+" or "-" button is released for more than 3 seconds, the new setting will be saved and the current hot water temperature will be displayed .

## Turning on/off the ice maker function



Ice maker function button

- Press and hold the “Ice making” button for more than 3 seconds to turn the ice maker off or on, the “OFF” red LED or the “ON” green LED will light.

### Turning on/off the hot water function

<b>NOTE</b>	<b>Normally the hot water function should be turned off to save energy.</b>
-------------	---



Hot water function button

- Press and hold the “Water heating” button for more than 3 seconds to turn the hot water off or on, the “OFF” red LED or the “ON” green LED will light.

### Turning on/off the light



Light button

- Press the “Light” button once to turn the light on. The light will automatically turn off in 5 minutes; press the button again to turn it off.

### Dispensing hot water

<b>NOTE</b>	<b>If the “Hot” button is pressed without unlocking, continuous short beeps will be heard. The “Hot” button will be locked automatically if it has been pressed for more than 40 seconds or once the button is released.</b>
-------------	--



Hot water dispensing button



Hot water unlocking button

- Place a cup under the water dispenser.
- Press the “Unlock” button once. You will hear a long beep indicating the “Hot” button is unlocked.
- Then press and hold “Hot” button within 5 seconds to dispense hot water.

### Dispensing room-temperature water

<b>NOTE</b>	<b>Water will stop dispensing automatically if the “Ambient” button has been pressed for more than 40 seconds.</b>
-------------	--





### Room-temperature water dispensing button

- Place a cup under the water dispenser.
- Press and hold the “Ambient” button to dispense room-temperature water.

### Dispensing ice

<b>NOTE</b>	<b>Ice dispenser will stop working while the freezer door is open. If ice cubes haven't been used for days, they may freeze together and unable to dispense. If this happens, pull out the ice bin and shake it, then push it in.</b>
-------------	---

### Dispensing cubed ice



### Cubed ice dispensing button

- Place a cup under the ice dispenser.
- Press and hold the “Cubed” button to dispense cubed ice.

### Dispensing crushed ice



### Crushed ice dispensing button

- Place a cup under the ice dispenser.
- Press and hold the “Crushed” button to dispense crushed ice.

### Resetting Water inlet valve



When the “Low” indicator appears, the water inlet valve, water heater, ice maker and water dispensers will stop working automatically.

- Activate the water inlet valve by pressing and holding “Light” button for more than 3 seconds until you hear a long beep and the inlet valve clicking. The “Low” indicator will flash and disappear automatically once the water tank is filled with water.

### Replacing water filters

<b>CAUTION</b>	<b>All water filters must be replaced at the same time. The filters should be replaced at least once a year.</b>
----------------	--

**FLr** When “FLr” flashes, replace the water filters immediately.

- Reset the "FLr" status by pressing and holding "Light" and "+" buttons for more than 6 seconds until you hear a long beep and "FLr" disappears.
- Dispense several cups of water to flush the system until water is clear.

### **Turn off the cooling system**

<b>NOTE</b>	<b>You may turn off the cooling system if you use only water dispenser. Please remove all ice before you turn it off.</b>
-------------	---

- Press and hold both "Light" and "-" buttons for more than 6 seconds until "OFF" flashes.
- Press "Light" button within 10 seconds to stop flashing for confirmation.

## DISPENSER CARE

<b>DANGER</b>	Unplug the unit or disconnect power before performing any maintenance.
<b>CAUTION</b>	If ice cubes block the feeler arm, clear the ice cubes before you pull out the ice bin. Move the feeler arm up and keep it above the ice bin while you pull out the ice bin. Otherwise the feeler arm may be damaged if it is obstructed by the ice bin.

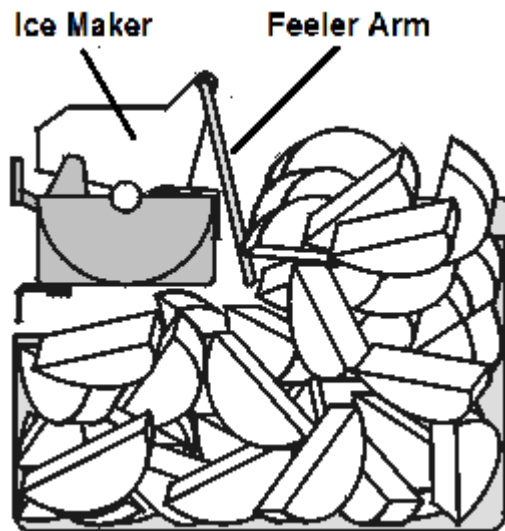

### How to empty ice bin

- Use the instructions below to remove the ice bin when emptying ice or cleaning the ice bin.

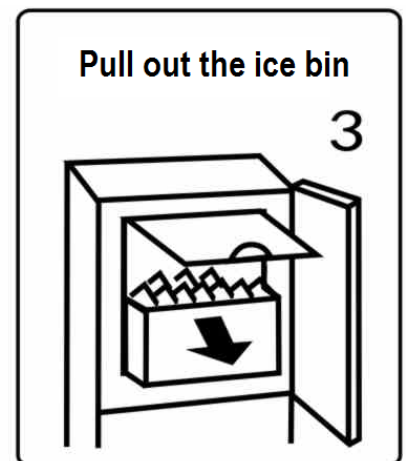
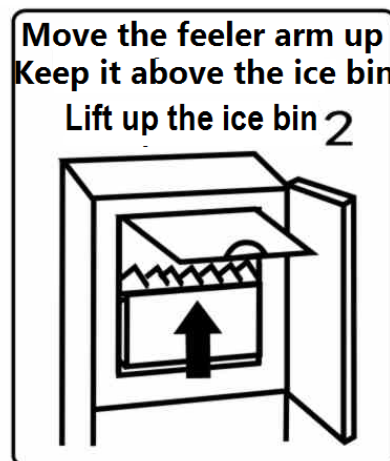
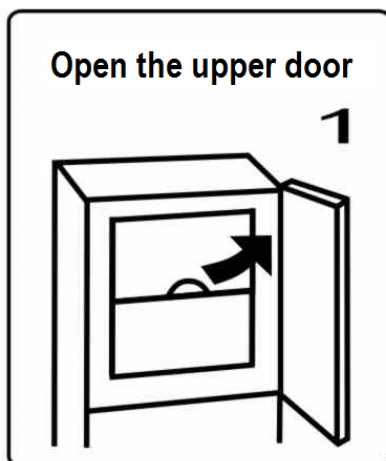

- Push the ice bin back until the auger is engaged in the auger coupler. If it is stuck, rotate the auger 1/8 turn, then push it in again.

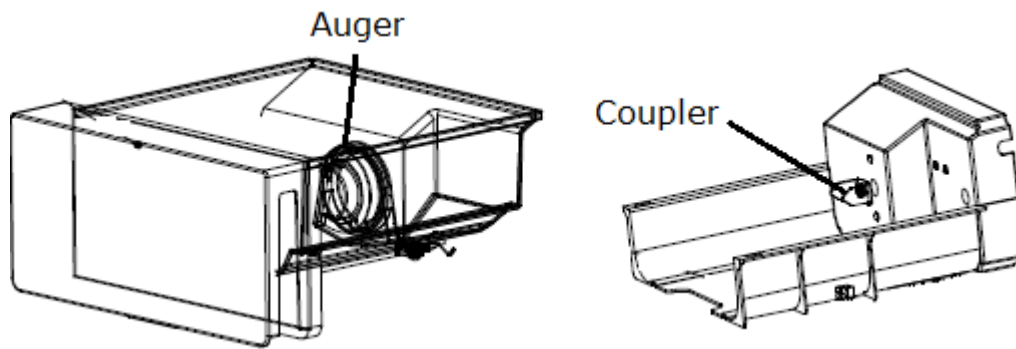

### **How to release water**

- Use the water release drain located at the back of the unit to release the remaining water.

### **If the dispenser does not dispense water**

- Air may be trapped.
- Release a cup of water from the water release drain.

### **How to remove condensate**

- The unit is operated with automatic defrost cycle. The water collects in a water tray that is located at the compressor compartment. Normally, the water evaporates through the hot gas tubing.
- In very high humidity conditions, manually empty water if the tray is full.

### **How to clean the water system with citric acid**

- Citric acid may be used if heavy sediment has built.
- Fill a 5 gallon container with cold water and add 1 lb of citric acid powder.
- Use ¼" OD tube to connect the container to the water line connector located at the back of the unit.
- Place the container above the unit to let the water flow into the internal water tank.
- Dispense the hot water to flush the system.
- Fill the container with clean cold water.
- Dispense the hot water to rinse the system until water is clear
- Release the remaining water.

### **When the "Low" indicator appears**

- Check if the water supply line is broken or the water inlet valve is defective; check all water tubes for leakages.
- Activate the water inlet valve by pressing and holding "Light" button for more than 3 seconds until you hear a long beep and the inlet valve clicking. The "Low" indicator will flash and disappear automatically once the internal water tank is filled with water.

### **If heavy frost builds up in the ice freezer**

- Press and hold the "Hot" button for more than 10 seconds until dEF is displayed. You will hear a long beep when the defrost cycle starts.

- Once the defrost cycle is complete, the hot water temperature will be displayed.

### **If ice cubes are frozen together**

- Press the “Cubed” or “Crushed” button to dispense ice for a few minutes.
- Open the upper door and pull out the ice bin to shake it or remove the large clumps of ice cubes.

### **If the ice bin is stuck**

- Unplug the unit.
- Use a hair dryer with warm or cold air to melt the ice.
- Pull out the ice bin and empty it.
- Wipe up water and put the ice bin back.
- Plug in the unit.

### **If ice cubes are jammed in the ice maker**

- Unplug the unit.
- Use a hair dryer with warm or cold air to melt the jammed ice cubes.
- Then remove the jammed ice cubes.
- Plug in the unit.

### **If a power outage happens**

- Unplug the unit.
- Pull out the ice bin and empty it.
- Wipe up water and put the ice bin back.

### **If you are away on holidays or vacations**

- Unplug the unit or disconnect the power.
- Open the upper door
- Pull out the ice bin and empty it.
- Let the freezer defrost.
- Wipe up water and dry the freezer.
- Release the remaining water.

### **What normal operating sounds you may hear**

- You may hear a boiling, rattling or gurgling sound produced by flow of refrigerant through the evaporator.
- You may hear air being forced through the unit by the evaporator fan.
- You may hear air being forced through the condenser by the condenser fan.
- You may hear a clicking sound produced by the refrigerant valve or dispensing valve.
- You may hear a water dripping sound during automatic defrost cycle.
- You may hear a high pitched hum or pulsating sound produced by the compressor.
- You may hear the ice cubes being ejected from the ice maker to the ice bin.

# INSTALLATION INSTRUCTIONS

## Location

<b>CAUTION</b>	<b>This unit is designed for only indoor use.</b>
----------------	---

- Place the unit away from direct sunlight and heat sources.
- Do not install the unit in moist areas.
- Do not install the unit in garage.
- Do not install the unit where the ambient temperature range will be below 50 °F or above 100 °F. Otherwise, the compressor will not be able to maintain proper temperature.
- The unit must be placed in a properly ventilated location to prevent heat build-up generated by the refrigeration system. Failure to do so will prevent the unit from cooling properly, and may result in damage to unit components as well as its contents.
- The unit must be installed on a counter that is level and strong enough to support a fully loaded unit up to 100 lb.

## Clearance

<b>CAUTION</b>	<b>This unit is designed for free-standing or recessed installation.</b>
----------------	--

- Allow for minimum 2" on the back, and 1" at the top for proper air circulation.
- If the unit is installed next to a fixed wall on the right side, leave 1" minimum clearance to allow the door to swing.
- Adjust the levelling legs to level the unit at a height that allows the door to be opened and closed properly.

## Electrical Requirements

<b>DANGER</b>	<b>It is required that you connect this unit only to a GFCI protected receptacle. It is strongly recommended that you do not use an adapter or an extension cord to connect this unit because of potential safety hazards.</b>
---------------	--

- A dedicated 115V, 60Hz, 15 or 20A fused, grounded electrical supply is required. It is recommended that a separate circuit serving only your appliance be provided.
- Only connect to properly polarized outlets.
- Use outlets that cannot be turned off by a switch.
- Only plug the unit into a grounded 3 prong outlet.

## How to insert or disconnect a tube or plug

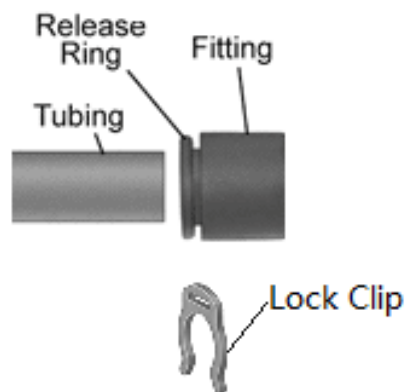

1. Remove the lock clip first.
2. To install, insert a tube or plug until it is engaged;  
To disconnect, press the release ring down and pull out a tube or plug.
3. Install the lock clip.

## Plumbed water line installation

### NOTE

A municipal water supply or other potable water with water pressure between 15 and 120 psig is required to operate this unit. Drain is not required.

- A. 1/4" OD tubing
- B. compression nut
- C. sleeves

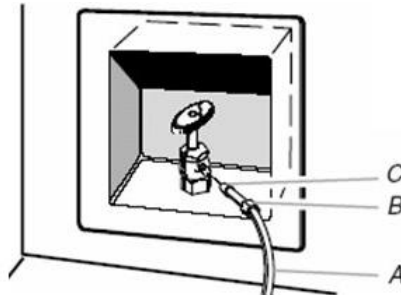
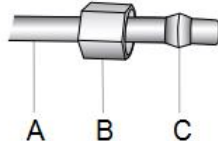

- Prepare a water supply line using 1/4" OD tubing (A) with a compression nut (B) and sleeves (C) on one end. Connect the tubing to the shutoff valve by screwing the compression nut.
- Place the free end of the tubing in a container or sink and turn the shutoff valve on to flush the tubing until water is clear. Then turn the shutoff valve off.



- Remove the plug of the plumbed water line connector (8), which is located at the back of the unit. Insert the free end of the tubing into the water line connector (8) until it is engaged.

### **Water filter installation**

- Remove the water filter cover (9) located at the back of the unit.
- To remove the filter, turn the filter counter-clockwise (a small amount of water may leak).
- To install the filter, turn the filter clockwise until it stops.

### **Parts for using plumbed filtered water**

<b>Description</b>	<b>Part No</b>	<b>Quantity</b>
1/4" OD Water Line W/ Compression Nut & Sleeves	0111700110	1
Water Filter Q5333	0182000100	1

### **External water filtration system**

If you use your own external water filtration system, connect the water outlet from such a system to the water line connector (7).



# TROUBLESHOOTINGS

## Charts

<b>Complaint</b>	<b>Possible Causes</b>	<b>Response</b>
<b>Unit is not working and display is not lit</b>	<ul style="list-style-type: none"> <li>a. Power cord is unplugged</li> <li>b. No power</li> <li>c. Power cord problems</li> <li>d. Control PCB is defective or wiring problems</li> <li>e. Display PCB is defective or wiring problems</li> </ul>	<ul style="list-style-type: none"> <li>a. Plug in the power cord</li> <li>b. Check for outlet and breaker or fuse</li> <li>c. Call for service</li> <li>d. Call for service</li> <li>e. Call for service</li> </ul>
<b>“Low” indicator appears (to reactivate the water inlet valve, press and hold “Light” button for more than 3 seconds)</b>	<ul style="list-style-type: none"> <li>a. The internal water tank is not filled with water yet</li> <li>b. The plumbed water supply line is broken</li> <li>c. Water pipes or tubes are loose, kinked or broken.</li> <li>d. The water inlet valve is defective or wiring problems</li> </ul>	<ul style="list-style-type: none"> <li>a. Reactivate the water inlet valve and wait until “Low” indicator disappears</li> <li>b. Fix it</li> <li>c. Tighten, straighten or change them.</li> <li>d. Call for service</li> </ul>
<b>Ice maker is not producing ice</b>	<ul style="list-style-type: none"> <li>a. The ice maker is not turned on</li> <li>b. Ice cubes are jammed</li> <li>c. The ice maker water tubes are kinked and the ice mould is not filled with water</li> <li>d. The water fill tube freezes</li> <li>e. The water filters are clogged</li> <li>f. The ice maker water pump is defective or wiring problems</li> <li>g. The ice maker is not working or wiring problems</li> <li>h. The cooling system is not working</li> </ul>	<ul style="list-style-type: none"> <li>a. Turn the ice maker on</li> <li>b. Clear the ice cubes</li> <li>c. Straighten them</li> <li>d. Unplug the unit and remove the ice bin; plug in again when the tube is free of ice.</li> <li>e. Remove the water filters and check if ice quality improves</li> <li>f. Call for service</li> <li>g. Call for service</li> <li>h. Call for service</li> </ul>
<b>Ice maker is not producing enough ice</b>	<ul style="list-style-type: none"> <li>a. The water supply line is kinked and the ice mould is not filled with sufficient water</li> <li>b. The water filters are clogged</li> <li>c. The freezer door is not sealed</li> <li>d. The ice maker water pump is defective</li> </ul>	<ul style="list-style-type: none"> <li>a. Straighten it</li> <li>b. Remove the water filters and check if ice quality improves</li> <li>c. Check for door seal and door opening</li> <li>d. Call for services</li> </ul>

	<ul style="list-style-type: none"> <li>e. The ice maker is not working properly</li> <li>f. The cooling system is not working properly</li> </ul>	<ul style="list-style-type: none"> <li>e. Call for service</li> <li>f. Call for service</li> </ul>
<b>Ice cubes are hollow or small</b>	<ul style="list-style-type: none"> <li>a. The water shutoff valve is not fully open</li> <li>b. The water supply line is kinked</li> <li>c. The water filters are clogged</li> <li>d. The ice maker water fill time is not enough</li> <li>e. The ice maker thermostat is defective</li> </ul>	<ul style="list-style-type: none"> <li>a. Turn the valve fully open</li> <li>b. Straighten it</li> <li>c. Remove the water filters and check if ice quality improves</li> <li>d. Call for service</li> <li>e. Call for service</li> </ul>
<b>Ice cubes are frozen together</b>	<ul style="list-style-type: none"> <li>a. If ice cubes haven't been used for a long period of time, they may freeze together</li> <li>b. Ice cubes are produced continuously because the feeler arm is blocked up</li> <li>c. The ice mould is overfilled because undersized ice cubes are left</li> </ul>	<ul style="list-style-type: none"> <li>a. Pull out the ice bin and shake it or remove the large clumps of ice cubes</li> <li>b. Clear ice cubes around the feeler arm</li> <li>c. Improve water pressure</li> </ul>
<b>Crushed ice is not dispensed</b>	<ul style="list-style-type: none"> <li>a. There are not enough ice cubes in the ice bin</li> <li>b. Ice cubes are frozen together on one side of ice bin</li> <li>c. The freezer door is open</li> <li>d. The magnetic switch is defective</li> <li>e. The auger motor is broken</li> <li>f. The flapper motor is broken or wiring problems</li> <li>g. Control PCB is defective or wiring</li> <li>h. Display PCB is defective or wiring problems</li> </ul>	<ul style="list-style-type: none"> <li>a. see <b>Ice maker is not producing ice &amp; Ice maker is not producing enough ice</b></li> <li>b. Pull out the ice bin and shake it</li> <li>c. Close it</li> <li>d. Replace it</li> <li>e. Call for service</li> <li>f. Call for service</li> <li>g. Call for service</li> <li>h. Call for service</li> </ul>
<b>Cubed ice is not dispensed</b>	<ul style="list-style-type: none"> <li>a. The solenoid is defective</li> <li>b. The same as crushed ice</li> </ul>	<ul style="list-style-type: none"> <li>a. Call for service</li> <li>b. See <b>Crushed ice is not dispensed</b></li> </ul>
<b>Hot water is not hot</b>	<ul style="list-style-type: none"> <li>a. The hot water function is not turned on</li> <li>b. The water heater stops working when "Low" indicator appears</li> <li>c. The water heater is broken</li> <li>d. The Thermostat is defective</li> </ul>	<ul style="list-style-type: none"> <li>a. Turn the hot water function on</li> <li>b. See <b>"Low" indicator appears</b></li> <li>c. Call for service</li> <li>d. Call for service</li> </ul>
<b>Hot water is not hot enough</b>	<ul style="list-style-type: none"> <li>a. The thermostat is defective</li> </ul>	<ul style="list-style-type: none"> <li>a. Call for service</li> </ul>
<b>Hot water heater smells</b>	<ul style="list-style-type: none"> <li>a. The hot water tank is dry</li> </ul>	<ul style="list-style-type: none"> <li>a. Call for service</li> </ul>

<b>burning</b>		
<b>Water dispenser is not working</b>	<ul style="list-style-type: none"> <li>a. The water dispensing valve automatically stops working when "Low" indicator appears</li> <li>b. Air is trapped</li> <li>c. The dispensing valve water tubes are kinked</li> <li>d. The water dispensing valve is defective</li> <li>e. Control or display PCB is defective or wiring problems</li> </ul>	<ul style="list-style-type: none"> <li>a. See "<b>Low</b>" indicator appears</li> <li>b. Release a cup of water from the water release drain</li> <li>c. Straighten them</li> <li>d. Call service</li> <li>e. Call service</li> </ul>
<b>Water dispensing is slow</b>	<ul style="list-style-type: none"> <li>a. The dispensing valve water tubes are kinked</li> <li>b. The water dispensing valve is defective</li> </ul>	<ul style="list-style-type: none"> <li>a. Straighten them</li> <li>b. Call service</li> </ul>
<b>Water is leaking</b>	<ul style="list-style-type: none"> <li>a. The dispenser drip tray is full</li> <li>b. Ice is being melted because of high freezer temperature</li> <li>c. The internal water tank is leaking</li> <li>d. The internal water tank level sensor is defective</li> <li>e. The water dispensing valve is defective</li> </ul>	<ul style="list-style-type: none"> <li>a. Empty it</li> <li>b. Check evaporator fan or wiring</li> <li>c. Call for service</li> <li>d. Call for service</li> <li>e. Call for service</li> </ul>
<b>Both freezer and ice maker evaporators are iced</b>	<ul style="list-style-type: none"> <li>a. The freezer door is not closed</li> <li>b. The defrost solenoid valve is defective or wiring problems</li> <li>c. The defrost drip tray heater is broken or wiring</li> <li>d. The evaporator fan is broken</li> </ul>	<ul style="list-style-type: none"> <li>a. Close it</li> <li>b. Call for service</li> <li>c. Call for service</li> <li>d. Call for service</li> </ul>

### Fault Messages

<b>Codes</b>	<b>Faults</b>	<b>Outputs</b>
<b>E01</b>	Defrost temperature probe is defective	Unchanged
<b>E02</b>	Freezer temperature probe is defective	Unchanged
<b>E03</b>	Hot water temperature probe is defective	Unchanged
<b>E04</b>	Hot water temperature is extremely high	Water heater is off
<b>E05</b>	Water level float switch is defective	Unchanged
<b>E06</b>	Freezer door is open	Unchanged
<b>E07</b>	Ice maker is not functioning properly	Unchanged
<b>E08</b>	Signals are no received by the control board	Unchanged
<b>E09</b>	Freezer temperature is extremely high	All outputs are off

## SERVICE & IMPORTANT NOTICE

The manufacturer has a policy of continuous improvement on its products and reserves the right to change materials and specifications without notice.

Contact us with any questions at 800-433-9938 or [info@floridaappliances.com](mailto:info@floridaappliances.com)

Or visit 24412 Main St. Suite 105 Carson, CA 90745 and  
[www.floridaappliances.com](http://www.floridaappliances.com)

**LIMITED WARRANTY:** Seller warrants that the goods will be free of defects in materials and workmanship for a period of 12 (twelve) months from date of sale, removal and re-installation of unit is not included in warranted labour. For a scratch and dent or refurbished unit, warranty is 3 months from your dated invoice (parts for function only, not cosmetic). There is no warranty on parts purchased separately. Purchaser's exclusive remedy is limited, at Seller's option; to repair or replace defective part[s] with either new or factory reconditioned part[s]. Purchaser is responsible for shipping the unit pre-paid to designated facility and Seller will pay return shipping charges in the continental United States for items repaired under warranty within 12 (twelve) months from date of sale. Improper placement of the unit will void the warranty. This limited warranty does not cover damage due to such things as accident, misuse, abuse, mishandling, neglect, acts of God, fires, earthquakes, floods, high winds, government, war, riot or labour trouble, strikes, lockouts, delay of carrier, unauthorized repair, or any other cause beyond the control of the Seller, whether similar or dissimilar to the foregoing. Seller is not responsible for any damages caused to Seller's property resulting from the good. This limited warranty applies only inside the Continental US. (Alaska, Puerto Rico and Hawaii are not warranted.)

Seller is not responsible for incidental or consequential damages, and there are no warranties, expressed or implied, which extend beyond the Limited Warranty described above. The implied warranties of merchantability and of fitness for a particular purpose are hereby expressly disclaimed. Some states do not allow the exclusion of incidental or consequential damages, or a waiver of the implied warranties of fitness and/or merchantability, so the above limitations may not apply to you. This warranty gives you specific legal rights and you may also have other rights which vary from state to state. In the event of any dispute between Seller and Purchaser arising out of or relating to these terms and conditions or to the goods sold generally, Purchaser must first file a written claim with Seller within ten days of the occurrence giving rise to the claim and wait an additional thirty days for a response before initiating any legal action. The sale and all terms are subject to Nevada law. Any legal proceeding arising out of or relating to these terms and conditions or to the goods sold generally shall be brought solely and exclusively in the City of Las Vegas. In no event may Purchaser initiate any legal proceeding more than six months after the occurrence of the event giving rise to the dispute.

The above terms and conditions are the only ones governing this transaction and Seller makes no oral representations of any kind. These Terms and Conditions can only be modified in writing, signed by both Purchaser and Seller.

FD is a registered trademark of Florida Appliances Inc. All products, features, and services are subject to change without notice. We cannot guarantee the accuracy of the contents of this document. We disclaim liability for errors, omissions, or future changes.  
Copyright©2015 Florida Appliances Inc. All rights reserved.